

# MIRAGE EXTERNAL MOUNT FLANGE FACING MACHINES

DIAMETERS FROM 0 - 80 INCH

CONTINUOUS GROOVE FINISHES  
TO ASME STANDARD



**ENERPAC** 

# Mirage Flange Facing Machines

**ENERPAC** 

▼ **MM760E** Externally mounted flange facing machine



- **Continuous variable auto-feed for ASME standard finishes**
- **Choice of pneumatic and hydraulic drive motors**
- **Quick-set radial clamping adjustment**
- **Quick-set axial adjustment jaws**
- **Heavy duty bearing construction for high metal removal rates and accuracy**
- **Heat exchanger kits for back facing and slot machining in one operation.**



**Included as Standard with Each Machine**

- Toolkit including tools and inserts
- Air filter lubricator (with pneumatic models)
- Hose connection
- All required mounting clamps
- Storage / shipping box
- CE certificate
- Packing list and manual



**Description**

A series of externally mounted robust flange facing machines used to produce continuous groove gramophone finishes to ASME Standard.

**Applications include**

Facing heat exchanger flanges and other large flanges such as crane pedestals.

Model Number	Drive Type	Facing Diameter (Standard Tooling)	Clamping Locators	Tool Post Stroke: X-axis	Tool Post Stroke: Z-axis	Max Rpm	Supply Required
MM760E	Pneumatic	0 – 762 mm (0 – 30")	4	0 – 356 mm (0 – 14")	0 - 102 mm (0 - 4")	16	6.2 bar (90 psi)
MM760E-H	Hydraulic						30 Lpm (8 Gpm) 55 bar (800 psi)
MM1000-E	Pneumatic	0 – 1016 mm (0 – 40")	4	0 – 356 mm (0 – 14")	0 - 102 mm (0 - 4")	12	6.2 bar (90 PSI)
MM1000E-H	Hydraulic						30 Lpm (8 Gpm) 55 bar (800 psi)
MM1250E	Pneumatic	0 – 1270 mm (0 – 50")	8	0 – 356 mm (0 – 14")	0 - 102 mm (0 - 4")	9	6.2 bar (90 psi)
MM1250E-H	Hydraulic						30 Lpm (8 Gpm) 55 bar (800 psi)
MM1500E	Pneumatic	0 – 1524 mm (0 – 60")	8	0 – 356 mm (0 – 14")	0 - 102 mm (0 - 4")	7	6.2 bar (90 psi)
MM1500E-H	Hydraulic						30 Lpm (8 Gpm) 55 bar (800 psi)
MM1775E	Pneumatic	0 – 1778 mm (0 – 70")	8	0 – 356 mm (0 – 14")	0 - 102 mm (0 - 4")	5	6.2 bar (90 psi)
MM1775E-H	Hydraulic						30 Lpm (8 Gpm) 55 bar (800 psi)
MM2000E	Pneumatic	0 – 2032 mm (0 – 80")	8	0 – 356 mm (0 – 14")	0 - 102 mm (0 - 4")	4	6.2 bar (90 psi)
MM2000E-H	Hydraulic						30 Lpm (8 Gpm) 55 bar (800 psi)

Model Number	Feed Rates X and Y-axis per rev
MM760E	0.1 – 0.8 mm (0.004 - 0.31")
MM76E-H	
MM1000E	0.1 – 0.8 mm (0.004 - 0.31")
MM1000E-H	
MM1250E	0.1 – 0.8 mm (0.004 - 0.31")
MM1250E-H	
MM1500E	0.1 – 0.8 mm (0.004 - 0.31")
MM1500E-H	
MM1775E	0.1 – 0.8 mm (0.004 - 0.31")
MM1775E-H	
MM2000E	0.1 – 0.8 mm (0.004 - 0.31")
MM2000E-H	

# External Mount Flange Facing Machines

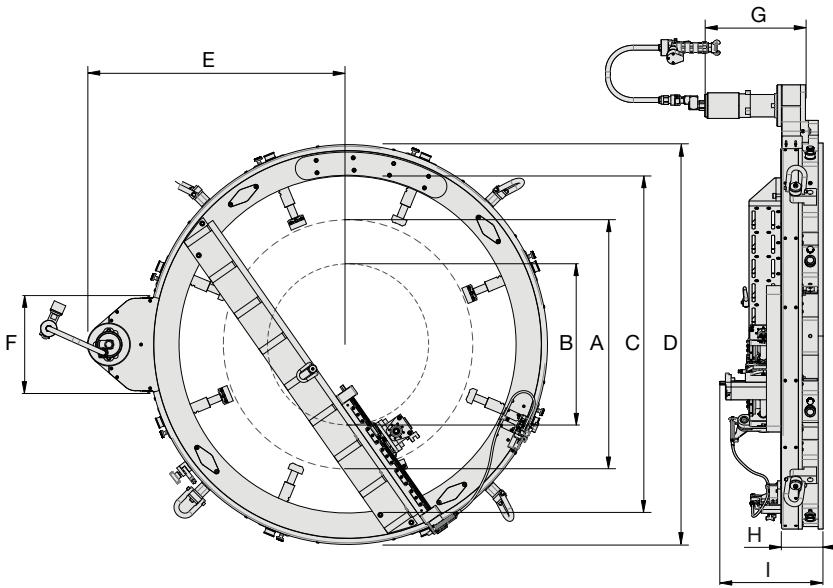

**MME**  
series



**0 - 80 inch**  
**External Mount**

FLANGE FACING MACHINES

Clamping Range:

**459 - 2045 mm (18.1 - 80.5")**

Facing Range:

**0 - 2032 mm (0 - 80")**

## MACHINE DIMENSIONS

	MM760E	MM1000E	MM1250E	MM1500E	MM1775E	MM2000E
<b>A</b> (clamping min-max)	459 - 775 mm (18.1 - 30.5")	714 - 1029 mm (28.1 - 40.5")	967 - 1283 mm (38.1 - 50.5")	1221 - 1537 mm (48.1 - 60.5")	1475 - 1791 mm (58.1 - 70.5")	1729 - 2045 mm (68.1 - 80.5")
<b>B</b> Clamping range with optional locator extensions	544 - 229 mm (21.4 - 9")	798 - 483 mm (31.4 - 19")	1052 - 737 mm (41.4 - 29")	1306 - 991 mm (51.4 - 39")	1560 - 1245 mm (61.4 - 49")	1814 - 1499 mm (71.4 - 59")
<b>C</b>	787 mm (31")	1041 mm (41")	1295 mm (51")	1549 mm (61")	1803 mm (71")	2057 mm (81")
<b>D</b> locator extensions	1085 mm (42.7")	1339 mm (52.7")	1593 mm (62.7")	1847 mm (72.7")	2101 mm (82.7")	2355 mm (92.7")
<b>E</b>	747 mm (29.4")	874 mm (34.4")	1001 mm (39.4")	1128 mm (44.4")	1255 mm (49.4")	1382 mm (54.4")
<b>F</b>	362 mm (14.25")	362 mm (14.25")	362 mm (14.25")	362 mm (14.25")	362 mm (14.25")	362 mm (14.25")
<b>G</b>	410 mm (16.1")	410 mm (16.1")	410 mm (16.1")	410 mm (16.1")	410 mm (16.1")	410 mm (16.1")
<b>H</b>	168 mm (6.6")	168 mm (6.6")	168 mm (6.6")	168 mm (6.6")	168 mm (6.6")	168 mm (6.6")
<b>I</b>	455 mm (17.9")	455 mm (17.9")	455 mm (17.9")	455 mm (17.9")	455 mm (17.9")	455 mm (17.9")

## SHIPPING DIMENSIONS

	MM760E	MM1000E	MM1250E	MM1500E	MM1775E	MM2000E
<b>Length</b>	1292 mm (51.3")	1582 mm (62.3")	1864 mm (73.4")	2145 mm (84.4")	2324 mm (91.5")	2464 mm (97")
<b>Width</b>	1346 mm (53")	1600 mm (63")	1880 mm (74")	2159 mm (85")	1803 mm (71")	1803 mm (71")
<b>Height</b>	660 mm (26")	660 mm (26")	660 mm (26")	660 mm (26")	1829 mm (72")	1981 mm (78")

## WEIGHTS

	MM760E	MM1000E	MM1250E	MM1500E	MM1775E	MM2000E
<b>Machine Weight</b>	401 kg (883 lbs)	469 kg (1033 lbs)	650 kg (1434 lbs)	722 kg (1591 lbs)	796 kg (1754 lbs)	886 kg (1953 lbs)
<b>Shipping Weight</b>	567 kg (1250 lbs)	665 kg (1466 lbs)	885 kg (1950 lbs)	1002 kg (2210 lbs)	1369 kg (3018 lbs)	1457 kg (3213 lbs)

# Mirage Flange Facing Machines

## The Range of Mirage Portable Machine Tools:

- Flange Facing Machines
- Hot Tapping Machines
- Portable Drilling Machines
- Decommissioning Saws
- Orbital Milling Machines
- Line Boring Machines
- Clamshell Pipe Cutters
- Custom Engineered Machines

## Enerpac Industrial Tools:

- Cylinders and Jacks
- Pumps and Valves
- Systems Components
- Bolting Tools
- Presses
- Pullers
- Tools
- Heavy Lifting Technology
- Equalizer Flange Maintenance Tools
- Biach Nuclear Tools
- Custom Products
- Workholding Tools

## Accessories for External Mount Flange Facing Machines

### Heat Exchanger Back Facing Module



Machine	Part Number
MM760E	<b>F0442C0001XX</b> for all machine sizes
MM1000E	
MM1250E	
MM1500E	
MM1775E	
MM2000E	

### Compatible Milling Rails



Machine	Compatible Milling Rail Part Number
MM760E	LMR1000
MM1000E	LMR1000
MM1250E	LMR1500
MM1500E	LMR1500
MM1775E	LMR2000
MM2000E	LMR2000

Please specify either hydraulic or pneumatic drive type along with the mounting bracket below.

### Spares Kits

Kit contains parts such as springs, bearings, feed nuts and a cam follower.

Machine	Part Number
MM760E	<b>MM760E-SK</b> for all machine sizes
MM1000E	
MM1250E	
MM1500E	
MM1775E	
MM2000E	

### Heat Exchanger Milling Rail Mounting Bracket

Part Number: **F0442D0002XX**  
for all machine sizes

### Face Turning Surface Comparator

Part Number: **RBC0119**

### Jaw Locator Leg

Part Number: **F0411A0005XX**  
For mounting onto smaller diameters

### Hose Couplings

Part Number: **F4027X0075HA**  
2 x ¾" quick release flat face couplings.  
Male and Female – 6 ft (1829 mm) hose length

Part Number: **F4027X0074HA**  
2 x ½" quick release flat face couplings.  
Male and Female – 6 ft (1829 mm) hose length

### Hydraulic Power Pack

Part Number: **HPU-2**  
3 Phase Electric



### Set up and operation

The operator must:

- Be trained and conversant with the product
- Be able to identify the correct and incorrect use of static or portable machines
- Comply with all local and internationally recognised safe use of powered machines.